

NON-POROUS HAND PRINTER ASSEMBLY

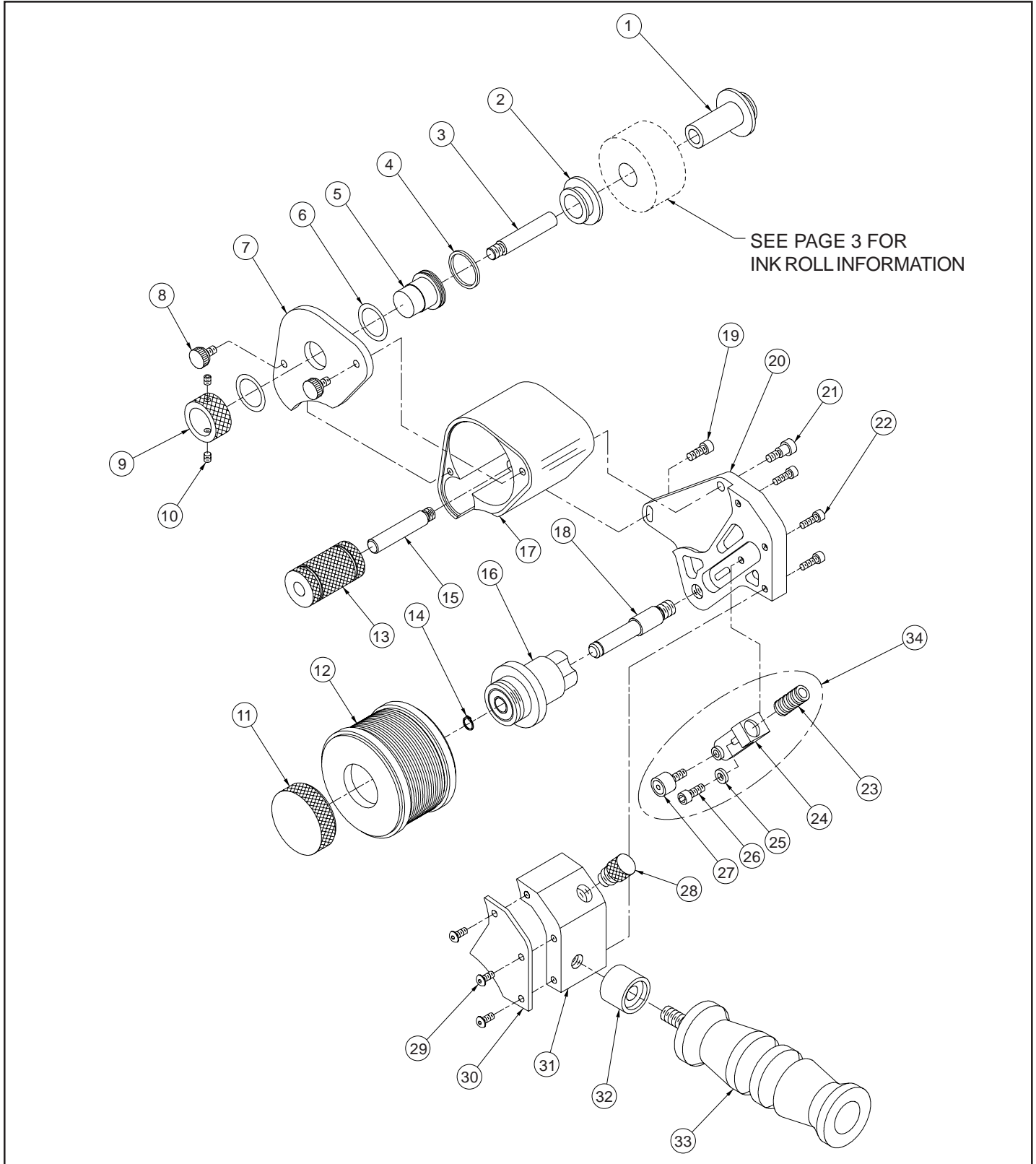

NON-POROUS HAND PRINTER PARTS LIST

KEY NO.	PART NUMBER	QTY. REQD.	DESCRIPTION
1	HPN-027	1	ROLLER CORE
2	HPN-028	1	ROLLER HUB
3	HPN-001	1	AXLE, INK ROLL
4	NP-21	1	O-RING, ECCENTRIC
5	HPN-007	1	ECCENTRIC
6	HP-42	2	DELTRIN WASHER
7	HPN-019	1	INKING SYSTEM HOUSING COVER
8	HPNP-TSA	2	THUMB SCREW ASSEMBLY
9	HPN-008	1	ECCENTRIC KNURLED KNOB
10	HP-06	2	SET SCREW, 8-32 X 3/16" CPS
11	HPN-022	1	KNURLED NUT, PRINT DRUM
12	HPNP-100-PDA	1	PRINT DRUM ASSEMBLY - STANDARD
	HPNP-100-PDA-T		PRINT DRUM ASSEMBLY - METRIC
13	HPN-004	1	TRANSFER ROLL, NON-POROUS HAND PRINTER
14	HPN-023	1	SNAP RING FOR 3/8" SHAFT
15	HPN-020	1	TRANSFER ROLL AXLE
16	HPNP-BHA	1	BEARING HUB ASSEMBLY
17	HPN-018	1	INKING SYSTEM HOUSING
18	HPN-002	1	AXLE, PRINT DRUM
19	CF-29	1	SCREW, 10-32 X 1/2" SHC
20	HPN-005	1	FRAME
21	HPN-029	1	FRAME HOUSING SHOULDER SCREW
22	MS-36	3	SCREW, 8-32 X 1/2" SHC
23	HPN-026	1	INDEX SPRING
24	HPN-013	1	INDEX SLIDE BRACKET
25	HPN-015	1	INDEX SLIDE DELTRIN WASHER
26	HPN-014	1	SCREW, 10-32 X 5/8" SHC
27	CB-06	1	BEARING, CAM ROLLER
28	HPN-016	1	TENSION ADJUSTING KNOB
29	MS-33	3	SCREW, 8-32 X 3/8" BHS
30	HPN-006	1	FRAME SIDE COVER
31	HPN-017	1	BACK FRAME
32	HP-17	1	BUSHING, HANDLE
33	HPNP-HA	1	HANDLE ASSEMBLY
*34	HPNP-ICA	1	INDEXING CONVERSION ASSEMBLY - HPNP

*INDEXING CONVERSION ASSEMBLY TO CONVERT NON-INDEXING MODELS TO INDEXING

NON-POROUS HAND PRINTER PRINT DRUM ASSEMBLY PARTS LIST

KEY NO.	PART NUMBER	QTY. REQD.	DESCRIPTION
1	MC-01S	2	O-RING, P.D. BEARER, SQUARE CUT
2	MC-43	1	RIBtype® RING 1-1/8" MC - STANDARD
	MC-43T		RIBtype® RING 1-1/8" MC - METRIC
3	HPN-003	1	PRINT DRUM - STANDARD
	HPN-003T		PRINT DRUM - METRIC

NON-POROUS HAND PRINTER PRINT DRUM ASSEMBLY

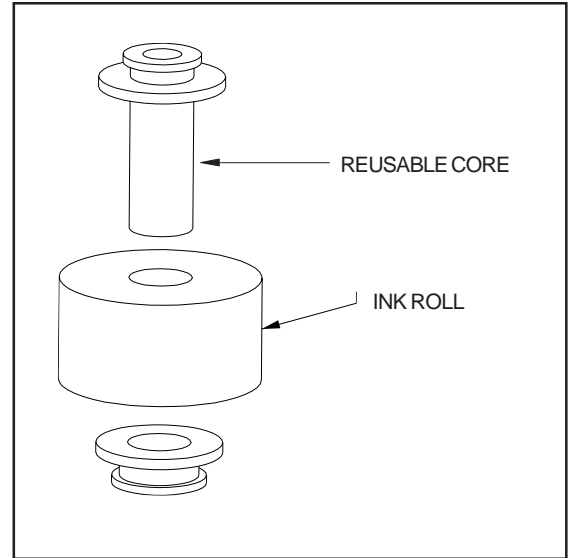
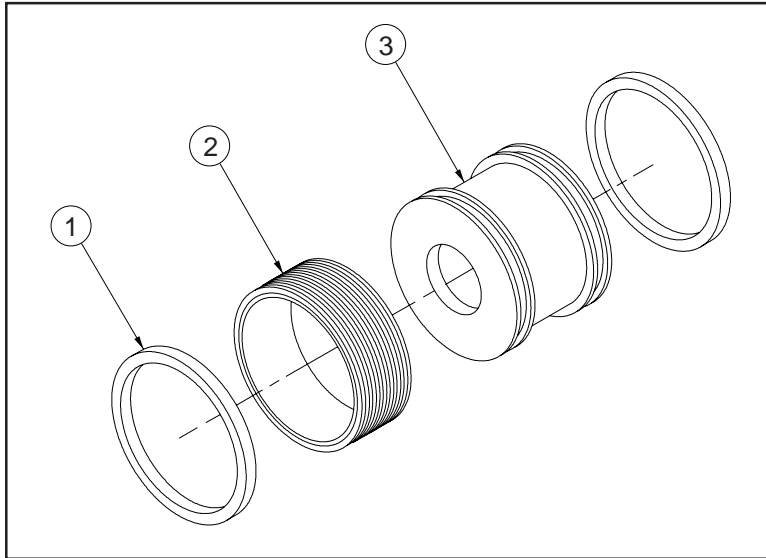

NON-POROUS HAND PRINTER REPLACEMENT INK ROLLS

DISPOSABLE TYPE MT INK ROLLS	
PART NUMBER	DESCRIPTION
HPNP-MT1-P1	NON-POROUS HAND PRINTER MT ROLL - BLACK
RE-INKABLE - XF NEOPRENE INK ROLLS	
<p>IMPORTANT! The core supplied with the Non-Porous Hand Printer is <i>reusable and should not be discarded with the roll sleeve</i>. The XF Neoprene Replacement Ink Rolls are <i>sleeves only and are sold separately</i>.</p>	
PART NUMBER	DESCRIPTION
HPNP-100RX	1" XF NEOPRENE REPLACEMENT SLEEVE
HPNP-100RX-P1	1" XF NEOPRENE REPL. SLEEVE - PRE-INKED BLACK
HPNP-100RX-P2	1" XF NEOPRENE REPL. SLEEVE - PRE-INKED RED
HPNP-100RX-P3	1" XF NEOPRENE REPL. SLEEVE - PRE-INKED GREEN
HPNP-100RX-P4	1" XF NEOPRENE REPL. SLEEVE - PRE-INKED BLUE
HPNP-100RX-P5	1" XF NEOPRENE REPL. SLEEVE - PRE-INKED YELLOW
HPNP-100RX-P6	1" XF NEOPRENE REPL. SLEEVE - PRE-INKED WHITE
HPNP-100RX-P9	1" XF NEOPRENE REPL. SLEEVE - PRE-INKED VIOLET

Universal Stenciling & Marking Systems, Inc.

P.O. Box 871 - St. Petersburg, FL 33731 - U.S.A.

Ph: (727) 894-3027 Fax: (727) 821-7944

E-Mail: sales@universal-marking.com Website: www.universal-marking.com