

October 10, 2006

**UNIVERSAL NON-POROUS CONVEYOR LINE PRINTERS
CLP-100 & CLP-200 SERIES**

NON-POROUS CONVEYOR LINE PRINTER CE GUARD ASSEMBLY

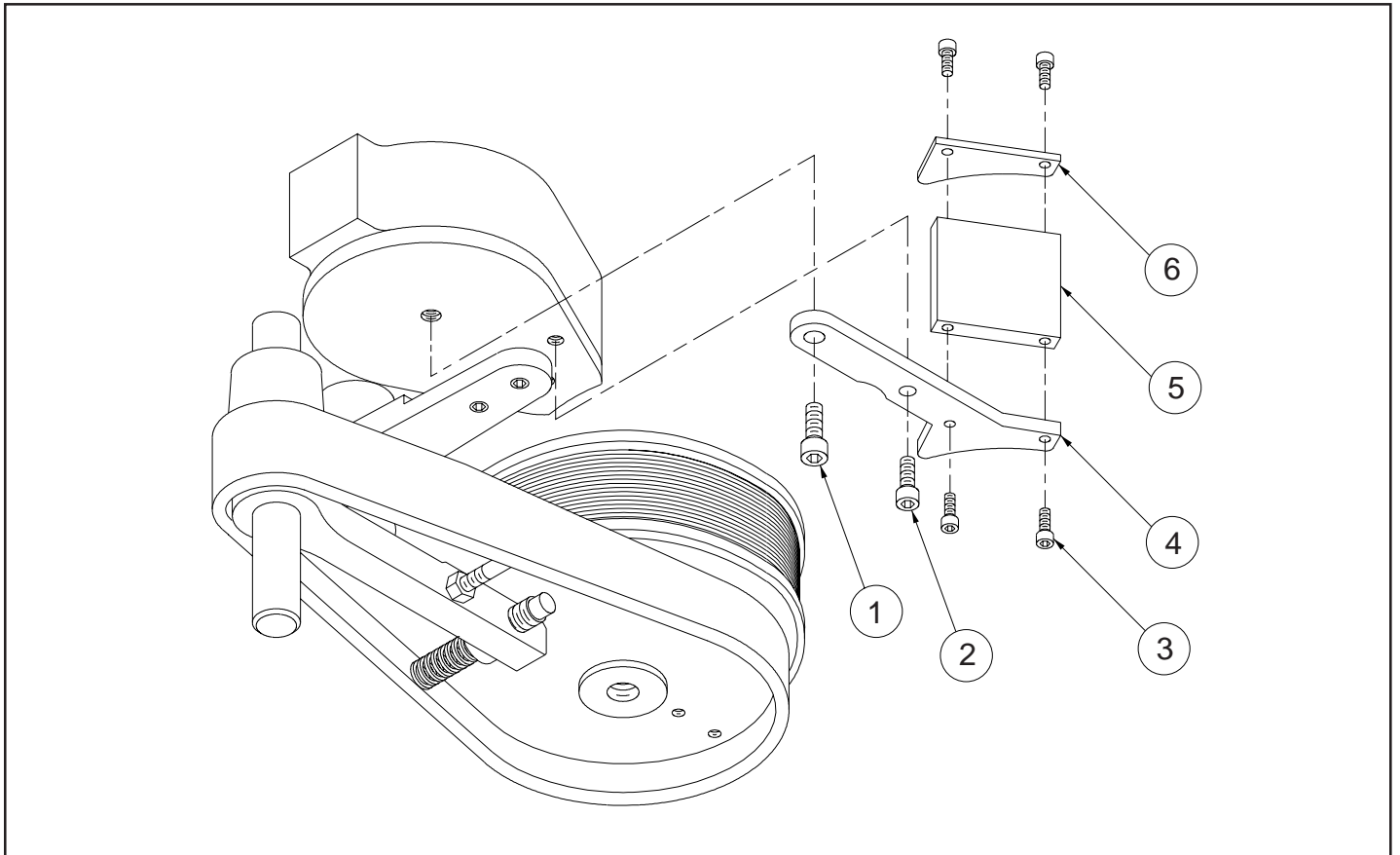

NON-POROUS CONVEYOR LINE PRINTER CE GUARD ASSEMBLY PARTS LIST

KEY NO.	PART NUMBER	QTY. REQD.	DESCRIPTION
1	CF-32	1	SCREW, 5/16-18 X 1/2" SHC
2	NP-23	1	SCREW, 1/4-20 X 1/2" SHC
3	MS-36	4	SCREW, 8-32 X 1/2" SHC
4	NP-70	1	MOUNTING ARM, CLP CE GUARD
5	NP-72	1	TOP PLATE, #100 CLP CE GUARD
	NP-73		TOP PLATE, #200 CLP CE GUARD
6	NP-71	1	END PLATE, CLP CE GUARD

NON-POROUS CONVEYOR LINE PRINTER ASSEMBLY

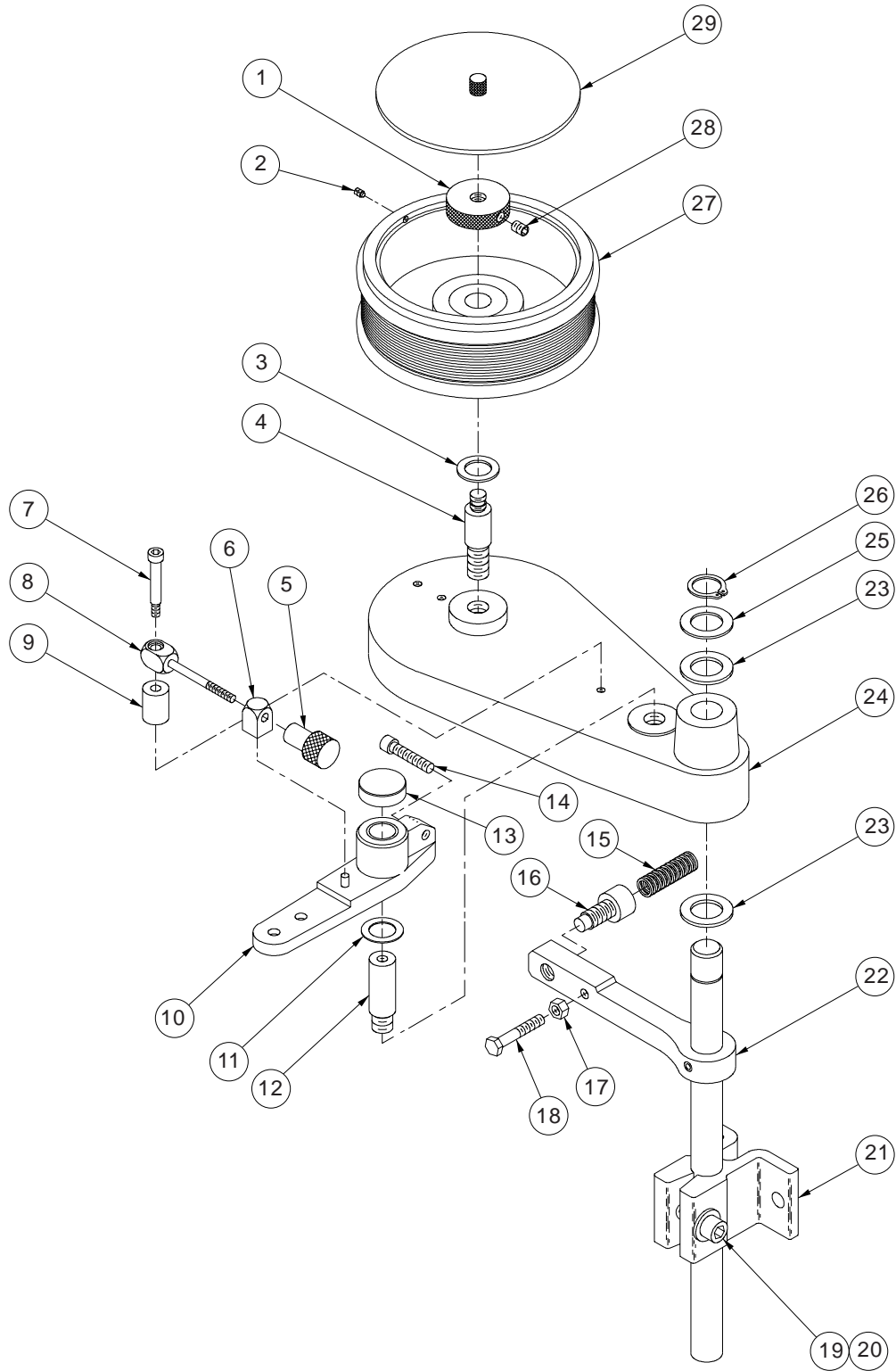

NON-POROUS CONVEYOR LINE PRINTER PARTS LIST

KEY NO.	PART NUMBER	QTY. REQD.	DESCRIPTION
1	CM-04	1	KNURLED RETAINING RING
2	CF-05	1	SET SCREW, 8-32 X 3/16" S.S. NPS
3	CW-03	1	WASHER, PRINT DRUM BRASS
4	CA-06	1	PRINT DRUM AXLE - 1"
	CA-02	1	PRINT DRUM AXLE - 2"
5	NP-18	1	KNOB, PIVOT ARM ADJUSTMENT
6	CM-27	1	BLOCK "A" PIVOT ARM
7	CF-26	1	SHOULDER SCREW
8	CLP-PAB	1	BLOCK "B" ASSEMBLY, PIVOT ARM
9	CM-26	1	PIVOT ARM POST
10	NP-28	1	PIVOT ARM ASSEMBLY, NON-POROUS
11	CW-04	1	WASHER, PIVOT ARM BRASS
12	CA-03	1	AXLE, PIVOT ARM
13	CM-16	1	CAP, PIVOT ARM
14	CF-02	1	SCREW, 1/4-20 X 1-1/4" SHC
15	CS-06	1	SPRING, TENSION ARM COMPRESSION
16	CM-25	1	TENSION ARM ADJUSTING CUP
17	CF-11	1	HEX NUT
18	CF-10	1	HEX BOLT
19	CF-09	1	SCREW, 3/8-16 X 1-1/2" SHC
20	CW-02	1	3/8" STEEL FLAT WASHER
21	CM-17	1	MOUNTING BRACKET
22	CLP-MCA	1	MOUNTING COLUMN ASSEMBLY
23	CW-05	2	3/4" NYLON FLAT WASHER
24	CC-01	1	BASE PLATE ASSEMBLY
25	CW-01	1	3/4" STEEL FLAT WASHER
26	CF-13	1	SNAP RING, FOR 3/4" SHAFT
27	CLP-100NI-NP-PDA	1	1" NON-INDEXING PRINT DRUM ASSEMBLY - COMPLETE
	CLP-100NP-PDA	1	1" INDEXING PRINT DRUM ASSEMBLY - COMPLETE
	CLP-200NI-NP-PDA	1	2" NON-INDEXING PRINT DRUM ASSEMBLY - COMPLETE
	CLP-200NP-PDA	1	2" INDEXING PRINT DRUM ASSEMBLY - COMPLETE
	CLP-100NI-NP-PDA-T	1	1" NON-INDEXING PRINT DRUM ASSEMBLY - COMPLETE - METRIC
	CLP-100NP-PDA-T	1	1" INDEXING PRINT DRUM ASSEMBLY - COMPLETE - METRIC
	CLP-200NI-NP-PDA-T	1	2" NON-INDEXING PRINT DRUM ASSEMBLY - COMPLETE - METRIC
	CLP-200NP-PDA-T	1	2" INDEXING PRINT DRUM ASSEMBLY - COMPLETE - METRIC
28	CF-04	1	SET SCREW, 1/4-20 X 3/8" BTS
29	CM-13	1	DUST COVER

NON-POROUS CONVEYOR LINE PRINTER INKING SYSTEM ASSEMBLY

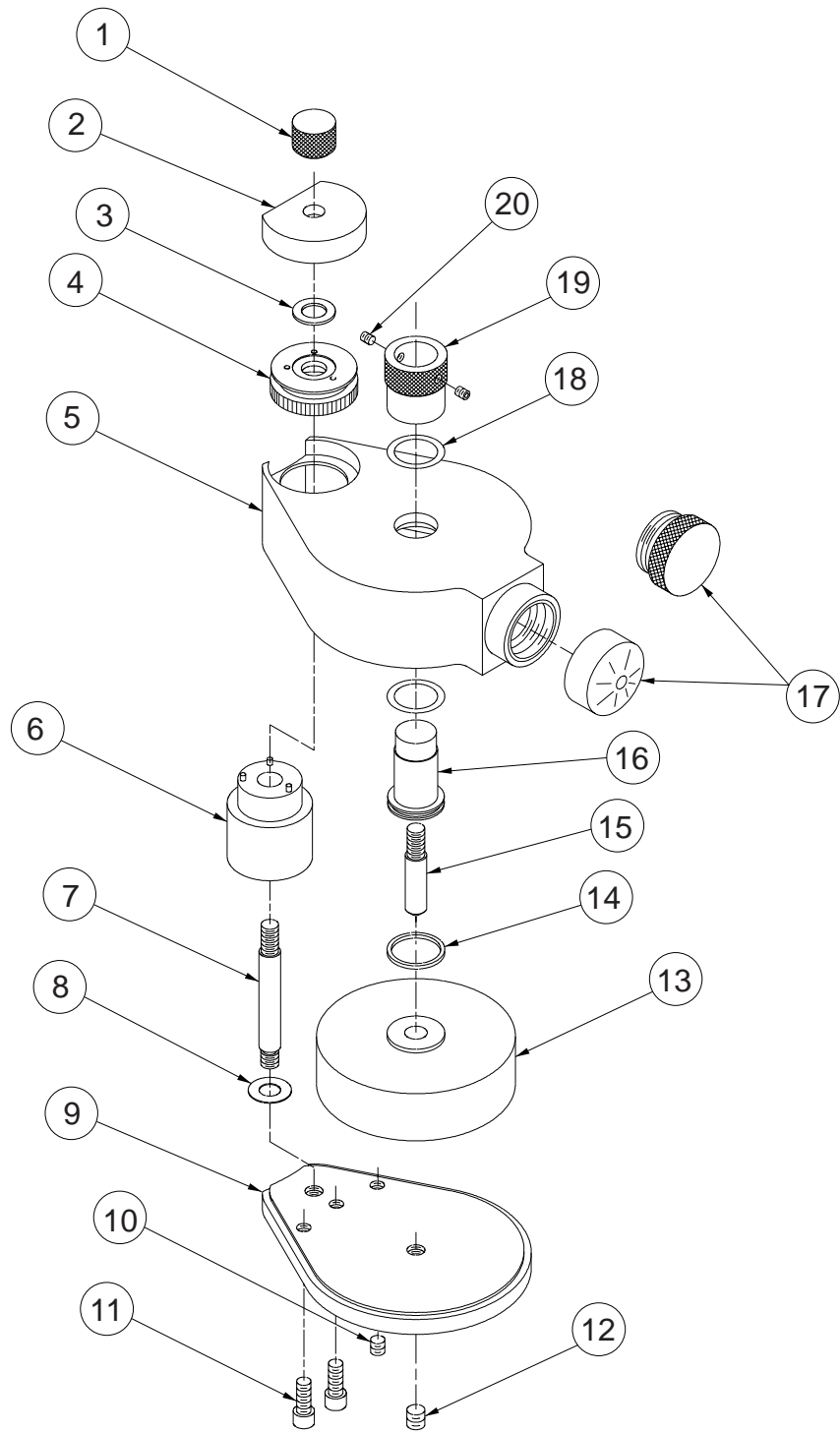

NON-POROUS CONVEYOR LINE PRINTER INKING SYSTEM PARTS LIST

KEY NO.	PART NUMBER	QTY. REQD.	DESCRIPTION
1	NP-17	1	COVER RETAINING KNOB
2	NP-16	1	DRIVE WHEEL COVER
3	NP-15	1	DELTRIN WASHER, DRIVE WHEEL
4	NP-14	1	KNURLED DRIVE WHEEL ASSEMBLY W/NP-15 DELTRIN WASHER
5	NP-01-CS	1	INKING SYSTEM COVER ASSEMBLY - SIDE MOUNT - CLP-100 SERIES
	NP-01-CT		INKING SYSTEM COVER ASSEMBLY - TOP MOUNT - CLP-100 SERIES
	NP-02-CS		INKING SYSTEM COVER ASSEMBLY - SIDE MOUNT - CLP-200 SERIES
	NP-02-CT		INKING SYSTEM COVER ASSEMBLY - TOP MOUNT - CLP-200 SERIES
6	NP-TRA-1	1	1" TRANSFER ROLL ASSEMBLY
	NP-TRA-2		2" TRANSFER ROLL ASSEMBLY
7	NP-05	1	1" CLP TRANSFER ROLL AXLE
	NP-06		2" CLP TRANSFER ROLL AXLE
8	HP-04	1	BRASS WASHER, PRINT DRUM
9	NP-03	1	CLP NON-POROUS INKING SYSTEM BASEPLATE
10	NP-31	1	SET SCREW, 1/4-20 X 3/8" FPS
11	NP-23	2	SCREW, 1/4-20 X 1/2" SHC
12	NP-24	1	SET SCREW, 5/16-18 X 3/8" FPS
13	NP-XC1	1	1" CLP XF NEOPRENE INK ROLL - DRY
	NP-XC2		2" CLP XF NEOPRENE INK ROLL - DRY
14	NP-21	1	O-RING, ECCENTRIC
15	NP-07	1	1" CLP INK ROLL AXLE
	NP-08		2" CLP INK ROLL AXLE
16	NP-20C	1	ECCENTRIC, INK ROLL
17	NP-29	1	BLACK VINYL CAP
	*NP-KRP		KNURLED RESERVOIR PLUG
18	HP-42	2	DELTRIN WASHER
19	NP-19	1	ECCENTRIC KNURLED KNOB
20	HP-06	2	SET SCREW, 8-32 X 3/16" CPS

*OPTIONAL THREADED PLUG WITH O-RING SEAL FOR RESERVOIR PORT

NON-POROUS CONVEYOR LINE PRINTER PRINT DRUM ASSEMBLY

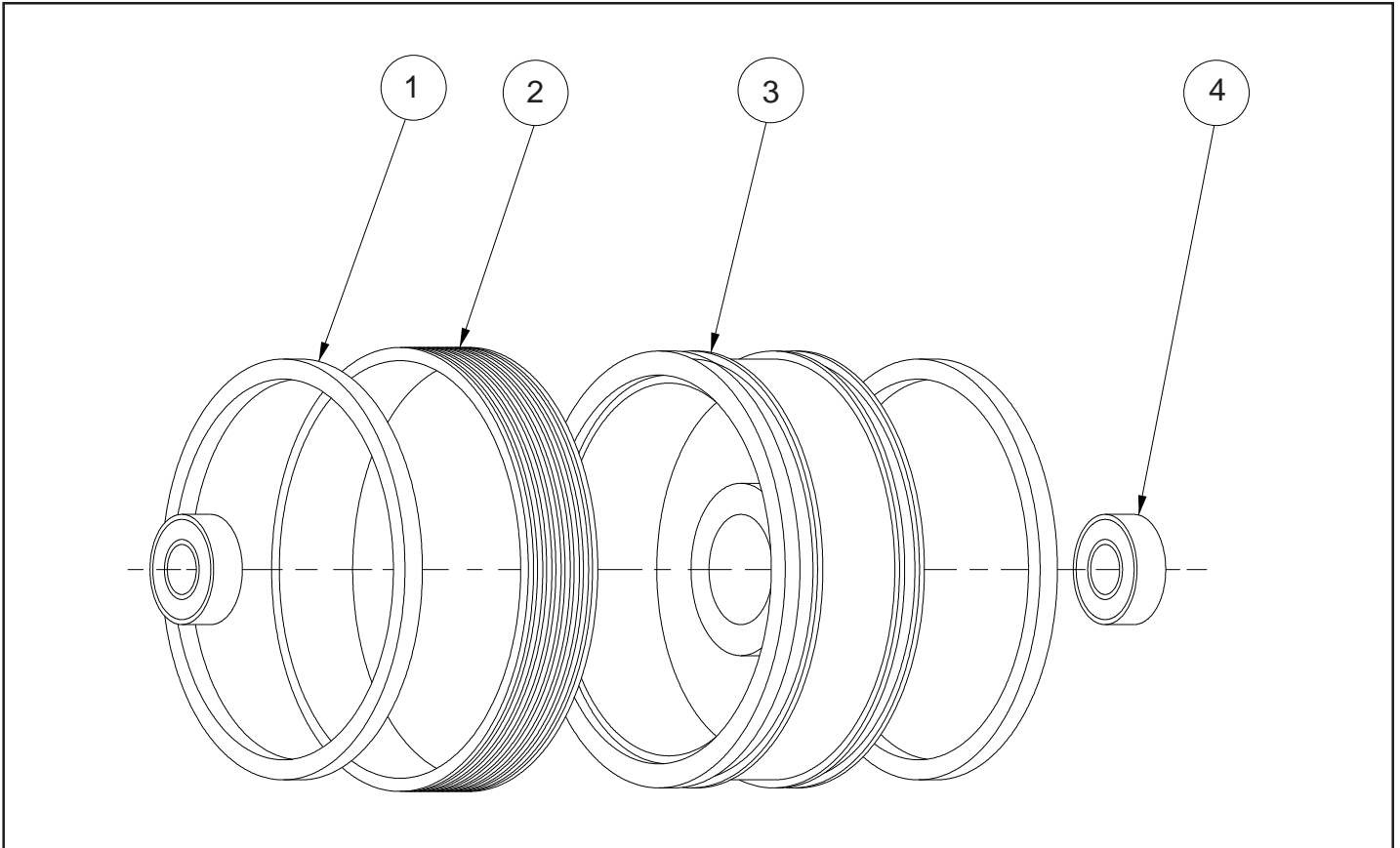

NON-POROUS CONVEYOR LINE PRINTER PRINT DRUM ASSEMBLY PARTS LIST

KEY NO.	PART NUMBER	QTY. REQD.	DESCRIPTION
1	CO-02S	2	FRICTION BEARER RING - SQUARE CUT
2	CLP-BL1	1	1" CLP RIBtype® RING
	CLP-BL2		2" CLP RIBtype® RING
	CLP-BL1T		1" CLP RIBtype® RING - METRIC
	CLP-BL2T		2" CLP RIBtype® RING - METRIC
3	CLP-PD1-NP	1	CLP-100 NON-INDEXING PRINT DRUM (W/CB-04 PRINT DRUM BEARINGS)
	CLP-PD1I-NP		CLP-100 INDEXING PRINT DRUM (W/CB-04 PRINT DRUM BEARINGS)
	CLP-PD2-NP		CLP-200 NON-INDEXING PRINT DRUM (W/CB-04 PRINT DRUM BEARINGS)
	CLP-PD2I-NP		CLP-200 INDEXING PRINT DRUM (W/CB-04 PRINT DRUM BEARINGS)
	CLP-PD1-NPT		CLP-100 NON-INDEXING PRINT DRUM (W/CB-04 PRINT DRUM BEARINGS) - METRIC
	CLP-PD1I-NPT		CLP-100 INDEXING PRINT DRUM (W/CB-04 PRINT DRUM BEARINGS) - METRIC
	CLP-PD2-NPT		CLP-200 NON-INDEXING PRINT DRUM (W/CB-04 PRINT DRUM BEARINGS) - METRIC
	CLP-PD2I-NPT		CLP-200 INDEXING PRINT DRUM (W/CB-04 PRINT DRUM BEARINGS) - METRIC
4	CB-04	2	PRINT DRUM BEARING

NON-POROUS CONVEYOR LINE PRINTER INDEX ASSEMBLY

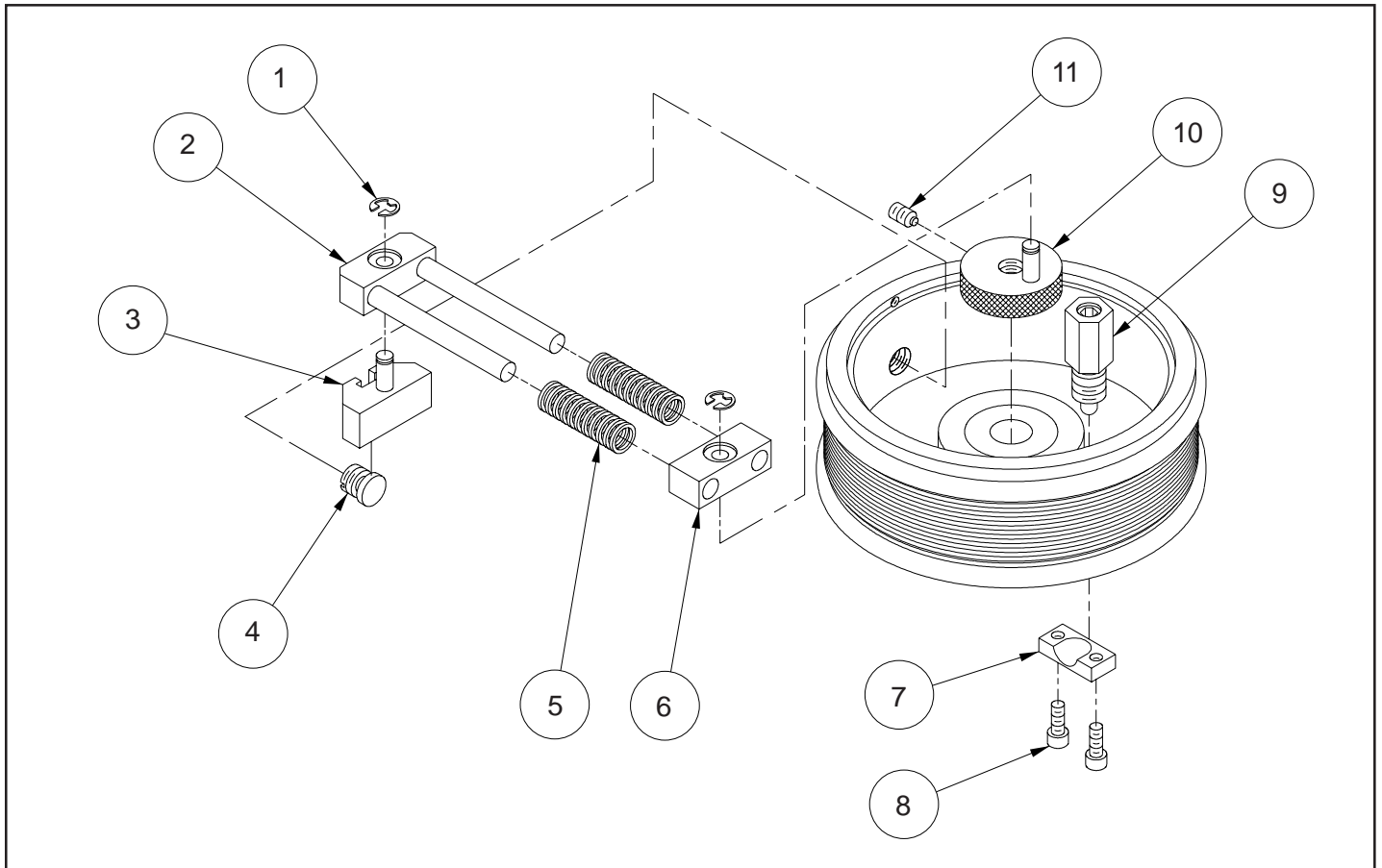

NON-POROUS CONVEYOR LINE PRINTER INDEX ASSEMBLY PARTS LIST

KEY NO.	PART NUMBER	QTY. REQD.	DESCRIPTION
1	CF-28	2	SNAP RING
2	CLP-IA	1	INDEX ASSEMBLY BLOCK "A"
3	CLP-IB	1	INDEX ASSEMBLY BLOCK "B"
4	CF-27	1	INDEX ASSEMBLY MOUNTING SCREW
5	CS-07	2	DRUM INDEX SPRING
6	CLP-IC	1	INDEX ASSEMBLY BLOCK "C"
7	CM-34	1	INDEX RAMP
8	CF-29	2	SCREW, 10-32 X 1/2" SHC
9	CLP-IP	1	INDEX PLUNGER ASSEMBLY
10	CLP-IR2	1	INDEX RING
11	CF-04	1	SET SCREW, 1/4-20 X 3/8" BTS

Universal Stenciling & Marking Systems, Inc.

P.O. Box 871 - St. Petersburg, FL 33731 - U.S.A.

Ph: (727) 894-3027 Fax: (727) 821-7944

E-Mail: sales@universal-marking.com Website: www.universal-marking.com