

Porous Mini-Coders

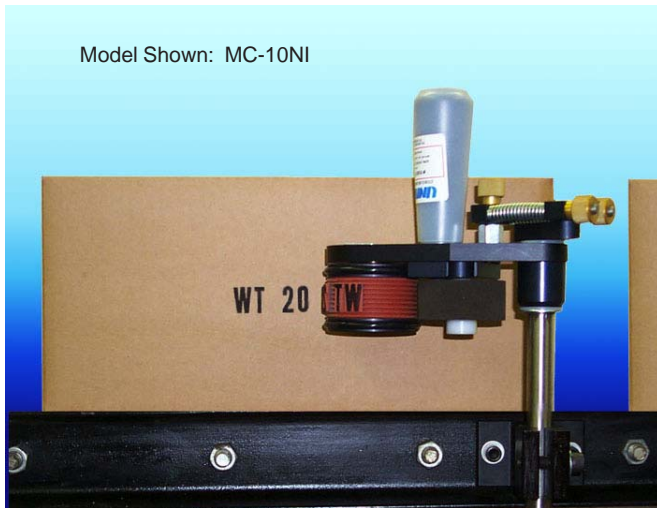

Model Shown: MC-10NI

Universal Mini-Coders are recommended for applications which require printing a small amount of code data on cartons or other flat surface materials. The unique inverted design enables the non-indexing Mini-Coder to print within 1/2" of the conveyor belt (within 1-1/8" of the conveyor belt with indexing models). Our patented dual compression spring tension mechanism allows the unit to be installed on either side of the conveyor line without modification.

To make type changes easy, all Mini-Coders are equipped with quick change print drums. The print drum axle contains a stainless steel spring plunger which retains the print drum during printing but also enables the print drum to be removed by pulling it off the axle without the use of tools. Additional print drums are available to facilitate off-line code changes without stopping production.

Universal's Reservoir Ink Cartridges plug right into the Mini-Coder for convenient, automatic re-inking of the ink roll during production. Standard models are supplied with Universal's RIBtype® die fastening system, a dry Microcell ink roll and an anodized aluminum mounting bracket.

Velcro die system and XF Neoprene ink rolls are optional.

SPECIFICATIONS

MC-10NI Non-Indexing Model

Print Area Approximately 1-1/8" x 9" / A= 1.125" (28.5 MM)
 B (Circumference) = 9.1" (231 MM) / C= 2.49" (63 MM)
 Net Weight: 4 LB. 12 OZ. (2.15 KG)

MC-10 Indexing Model

Print Area Approximately 1-1/8" x 9" / A= 1.125" (28.5 MM)
 B (Circumference) = 9.1" (231 MM) / C= 2.49" (63 MM)
 Net Weight: 5 LB. (2.27 KG)

MC-20NI Non-Indexing Model

Print Area Approximately 2" x 9" / A= 2" (50.8 MM)
 B (Circumference) = 9.1" (231 MM) / C= 3.37" (86 MM)
 Net Weight: 5 LB. 2 OZ. (2.32 KG)

MC-20 Indexing Model

Print Area Approximately 2" x 9" / A= 2" (50.8 MM)
 B (Circumference) = 9.1" (231 MM) / C= 3.37" (86 MM)
 Net Weight: 5 LB. 7 OZ. (2.47 KG)

FEATURES

- Sealed ball bearings for smooth print drum rotation.
- Precision ground stainless steel mounting columns for corrosion resistance and ease of adjustment.
- Re-inkable Microcell rollers that last up to one year with daily use.
- Mount on the left or right side of conveyor line without conversion.
- Reservoir inking system applies ink to roll on demand, not a gravity feed system.

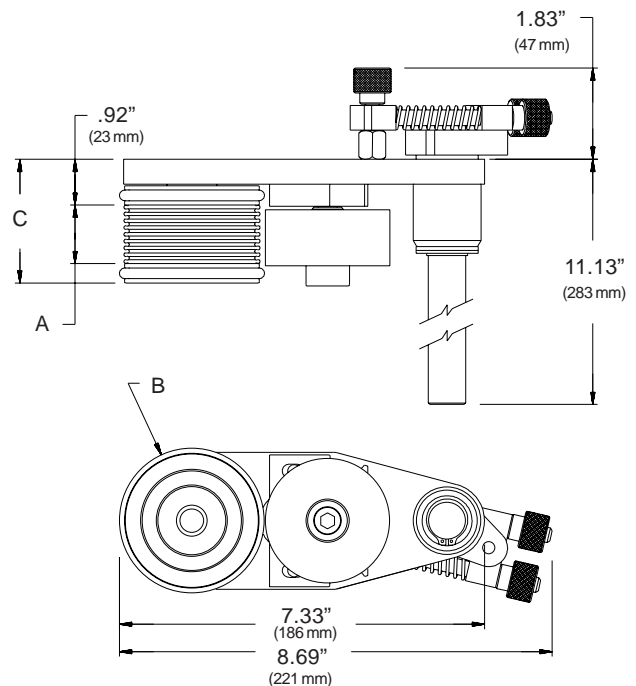

Manufactured By
Universal Stenciling & Marking Systems, Inc.

P.O. Box 871 - St. Petersburg, FL 33731 - U.S.A.

Ph: (727) 894-3027 Fax: (727) 821-7944 E-Mail: sales@universal-marking.com Website: www.universal-marking.com