

Non-Porous Mini-Coder

U.S. PATENT NO. 5,109,769 E.P. PATENT NO. 0508971

Universal offers a breakthrough in non-porous coding technology. Unmatched in quality and performance, our patented Non-Porous Inking System design completely eliminates the problems associated with the use of fast drying inks on non-porous materials like plastics, metal, rubber, glass, varnished and waxed cartons, etc.

The inking system on these coders is completely enclosed to prevent solvent evaporation and unlike flexographic systems, there is no open well of ink. Remarkably, no maintenance is required during or at the end of each production shift which makes these printers the most trouble free on the market.

In operation, a pre-inked roll in the inking system housing applies ink to a finely engraved anilox roll which then meters a thin film of ink to the face of the printing dies. When the ink capacity of the roll is depleted, the roll can be re-inked automatically during production by installing one of our disposable 4 oz. Reservoir Ink Car-



Precision engineered, remarkably versatile and reliable, this new system is revolutionizing the non-porous printing process.

The Ultimate In Non-Porous Roll Coding Technology!

FEATURES

- Consistent, high quality printing on non-porous materials with a drying time as fast as 2 seconds.
- Available in both top mounted styles for web printing and side mounted styles for cartons and other conveyed products.
- Outstanding performance even with fast drying, pigmented, government spec. inks.
- Precision machined from aircraft grade aluminum alloys and stainless steel for minimal maintenance and superior long term performance.
- Sealed ball bearings in print drum and anilox roll provide smooth rotation
- Quick change print drums can be pulled off the axle without the use of tools for off-line code changes.

SPECIFICATIONS

Print Drum Circumference: 9.1" (231 mm)
 Maximum Print Width: 1.0" (25.4mm)
 Die System: Universal RIBtype® Die System
 Weight: 6 Lbs - 15 Oz. (3.15 Kg)

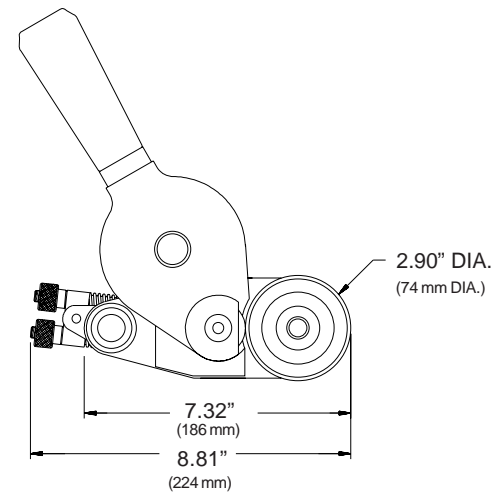
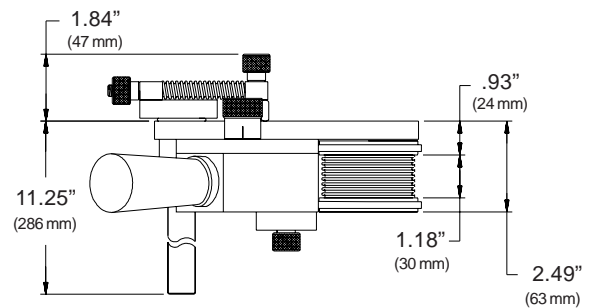

Manufactured By

Universal Stenciling & Marking Systems, Inc.

P.O. Box 871 - St. Petersburg, FL 33731 - U.S.A.

Ph: (727) 894-3027 Fax: (727) 821-7944 E-Mail: sales@universal-marking.com Website: www.universal-marking.com