

Porous Hand Printer



Universal's Hand Printers are designed to provide an efficient, manual method of printing date codes, product I.D.'s, lot numbers or other shipping & handling data. This lightweight hand coder is ideal for use in the shipping room or the warehouse where automatic coding is not possible.

Heavy duty construction includes an anodized aircraft aluminum frame, sealed ball bearings and an eccentric ink roller adjustment. Standard features include a dry Microcell re-inkable roll and Universal's versatile RIBtype® die fastening system. RIBtype® rubber type makes changing codes & other data quick and easy, minimizing costly down time.

*Custom sizes are available for special applications.
Note: The porous Hand printer's are not recommended for regular usage with alcohol based inks.*

These units are designed for use with Universal #1150 coder ink for marking on cardboard and other porous materials. A variety of other inks are available for special applications.

Non-indexing Hand Printers continuously print at repeat intervals equal to the drum circumference. The print drum on the indexing printer returns to the same start position after each rotation, allowing for accurate print registration.

FEATURES

- Lightweight anodized aircraft aluminum frame.
- Sealed ball bearings for smooth print drum rotation. (Non-indexing printers)
- Impact resistant plastic handle - Extension handles are available.
- Re-inkable Microcell roller.
- Eccentric adjustment for ink roll to die face contact.
- Universal RIBtype® die system accommodates logo dies and individual characters.

Stock Printers are equipped with Universal's RIBtype® Die System & Microcell Roll.

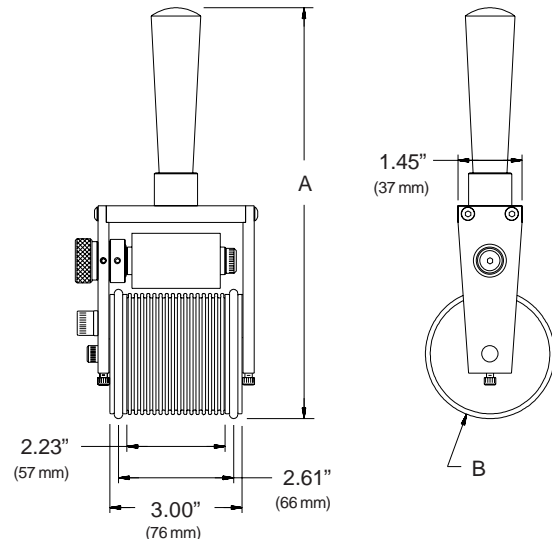

SPECIFICATIONS

HP-100NI Small Non-Indexing Model

Print Area Approximately 2" x 6.5"
A: 8.4" (213 MM) B: Circumference = 6.5" (165 MM)
Net Weight - 1 LB. 11 OZ. (.77 KG)

HP-200NI Large Non-Indexing Model

Print Area Approximately 2" x 9"
A: 9.3" (236 MM) B: Circumference = 9.1" (231 MM)
Net Weight - 1 LB. 11 OZ. (.77 KG)

HP-200 Large Indexing Model

Print Area Approximately 2" x 9"
A: 9.3" (236 MM) B: Circumference = 9.1" (231 MM)
Net Weight - 1 LB. 10.5 OZ. (.74 KG)

Manufactured By

Universal Stenciling & Marking Systems, Inc.

P.O. Box 871 - St. Petersburg, FL 33731 - U.S.A.

Ph: (727) 894-3027 Fax: (727) 821-7944 E-Mail: sales@universal-marking.com Website: www.universal-marking.com