

Porous Conveyor Line Printers

AUTOMATIC PRINTING HAS NEVER BEEN SO EASY!

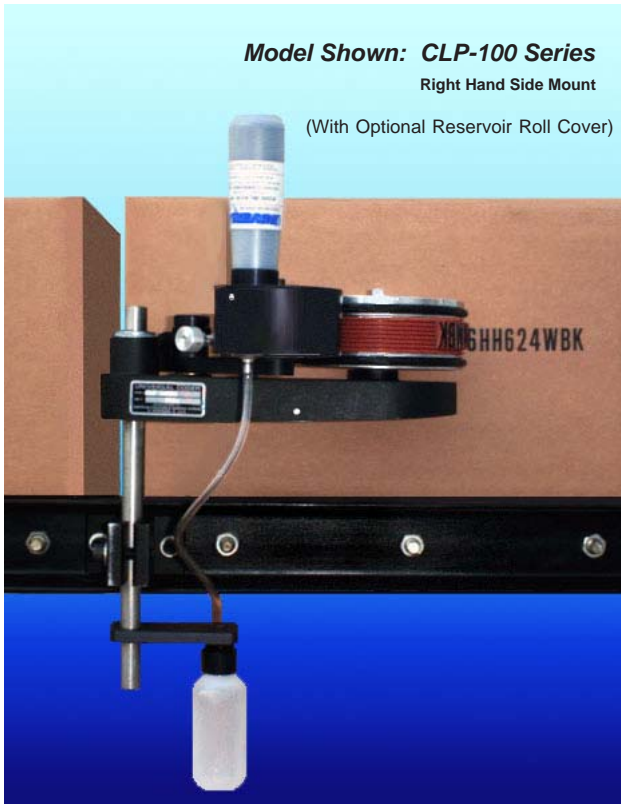

Universal's Conveyor Line Printers automatically print data on moving cartons and other flat surfaced materials with unsurpassed accuracy and legibility. These machines are mounted right on the conveyor line and require no power or operator assistance to print high quality impressions thousands of times a day.

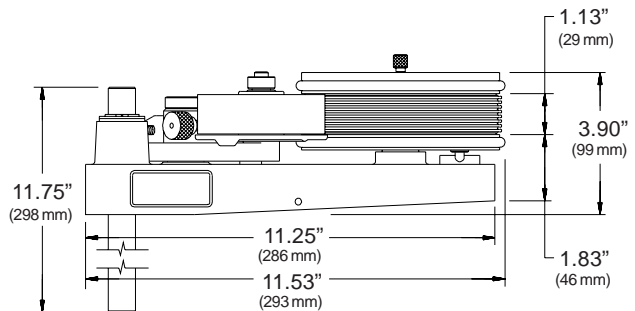
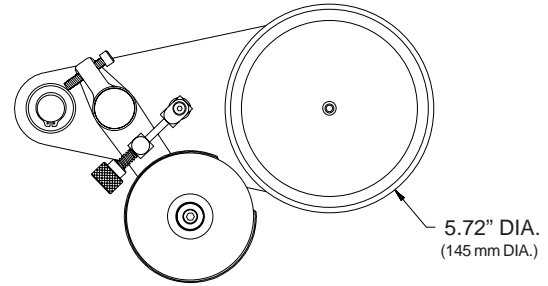

ALSO AVAILABLE IN 2", 3" & 4" PRINT WIDTH MODELS

Exclusive Features

- Indexing (spot printing) and non-indexing (continuous printing) models with print areas up to 4" x 17-1/2".
- Field convertible mounting configuration for printing on the top, sides or bottom of the product.
- Precision machined, impact resistant aluminum castings with polyurethane finish for corrosion resistance.
- Permanently lubricated, sealed ball bearings in the print drum for extremely accurate, low friction drum rotation.
- Stainless steel mounting columns and shafts for durability even in harsh environments.
- Indexing mechanism with dual compression springs mounted over stainless steel guide rods prevents spring breakage and provides unsurpassed indexing speed and accuracy.
- Universal's RIBtype[®] die system allows text information to be set using individual characters or one piece logo dies. Custom dies can also be produced from camera ready copy.

Optional Features

To eliminate the task of manually re-inking the ink roll, optional Reservoir Roll Covers can be added to the coder. These covers, which are available for all coder models, accommodate our disposable 4 oz. Reservoir Ink Cartridges. Simply add the appropriate size roll cover and a 4 oz. disposable ink cartridge and the ink roll will be automatically re-inked during the printing operation. Universal's Reservoir Inking System feeds ink only when the machine is actively printing. Please note that the ink roll on the coder must be pre-inked prior to installing a 4 oz. Reservoir Ink Cartridge.

Manufactured By

Universal Stenciling & Marking Systems, Inc.

P.O. Box 871 - St. Petersburg, FL 33731 - U.S.A.

Ph: (727) 894-3027 Fax: (727) 821-7944 E-Mail: sales@universal-marking.com Website: www.universal-marking.com