



**OWNER'S MANUAL**

**POROUS  
HAND PRINTER  
ALL MODELS**

**OPERATION - MAINTENANCE**



**UNIVERSAL STENCILING & MARKING SYSTEMS, INC.**

P.O. BOX 871 - ST. PETERSBURG, FLORIDA 33731 USA

PH: (727) 894-3027 FAX: (727) 821-7944

E-Mail: [sales@universal-marking.com](mailto:sales@universal-marking.com) Website: [www.universal-marking.com](http://www.universal-marking.com)

## **IMPORTANT NOTE**

UNIVERSAL products are manufactured to exacting standards and every available step has been taken to assure your complete satisfaction. It is most important, however, that the instructions contained in this manual are read and carefully followed for best results. Failure to do so may result in unsatisfactory performance, damage to the equipment and personal injury.

### **TABLE OF CONTENTS**

#### **SPECIFICATIONS**

HP-100NI. . . . .	3
HP-200. . . . .	4
HP-200NI. . . . .	4
Printing Die's. . . . .	5
Optional Type Blocking Kit. . . . .	6
Ink Rolls & Inks. . . . .	6

#### **QUICK START**

Pre-inking the Microcell Ink Roll. . . . .	7
Re-inking the Microcell Ink Roll. . . . .	9

#### **MAINTENANCE**

Replacing the Drum Covering. . . . .	10
Replacing the Print Drum Index Spring on the HP-200 Indexing Coder	12
Adjusting the tension of the Index Spring. . . . .	16
Assembly of the Ink Roller Eccentric. . . . .	18

PARTS DIAGRAMS & PARTS LISTS . . . . .	20
--	----

### **- LIMITED WARRANTY -**

UNIVERSAL Hand Printers are guaranteed to be free from defects in materials and workmanship for a period of 90 days from the date of purchase. Components found to be defective during this time will be repaired free of charge if returned to the factory. Damage resulting from use of improper inks, improper installation, or operation is not covered under the scope of this warranty. For warranty service please contact our Customer Service Department.

## SPECIFICATIONS

### HP-100NI HAND PRINTER

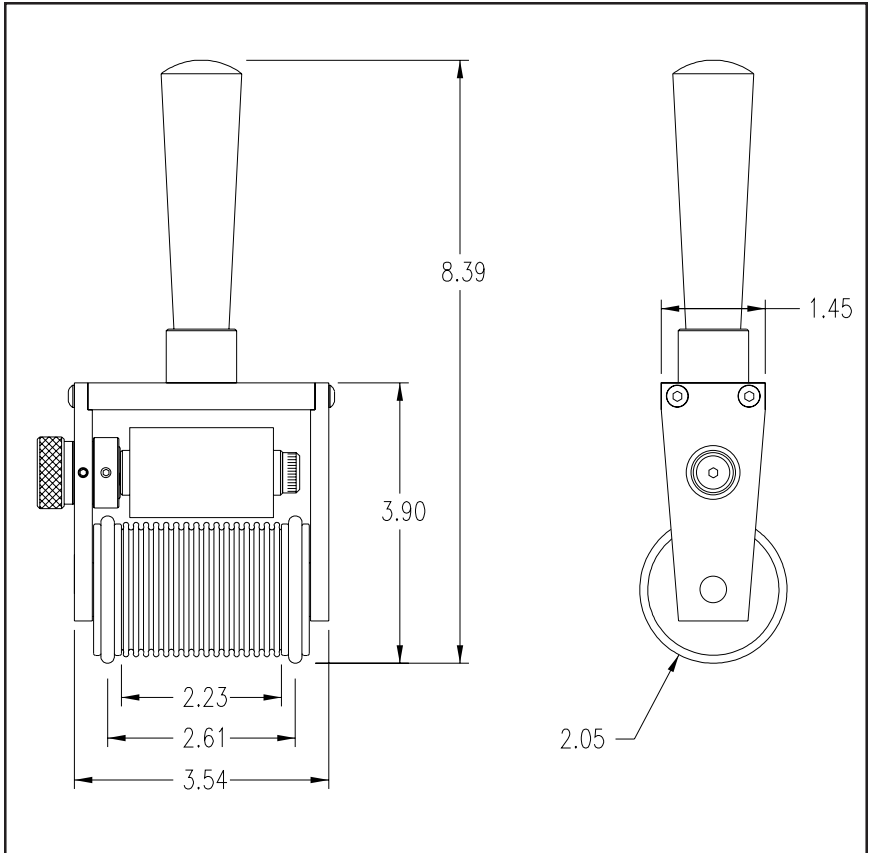

**NET WEIGHT:** 1LB - 6 OZ. / 0.614 KG.

**MAXIMUM DIE SIZE - US STANDARD:** 2" (15 RIBS) X 5-9/16" LONG

**MAXIMUM DIE SIZE - METRIC CODERS ONLY:** 50.8 MM (14 RIBS) X 141.3 MM LONG

**PRINT DRUM CIRCUMFERENCE:** 6.5" (165 MM) MEASURED AT DIE FACE

## SPECIFICATIONS

### HP-200 & HP-200NI HAND PRINTER

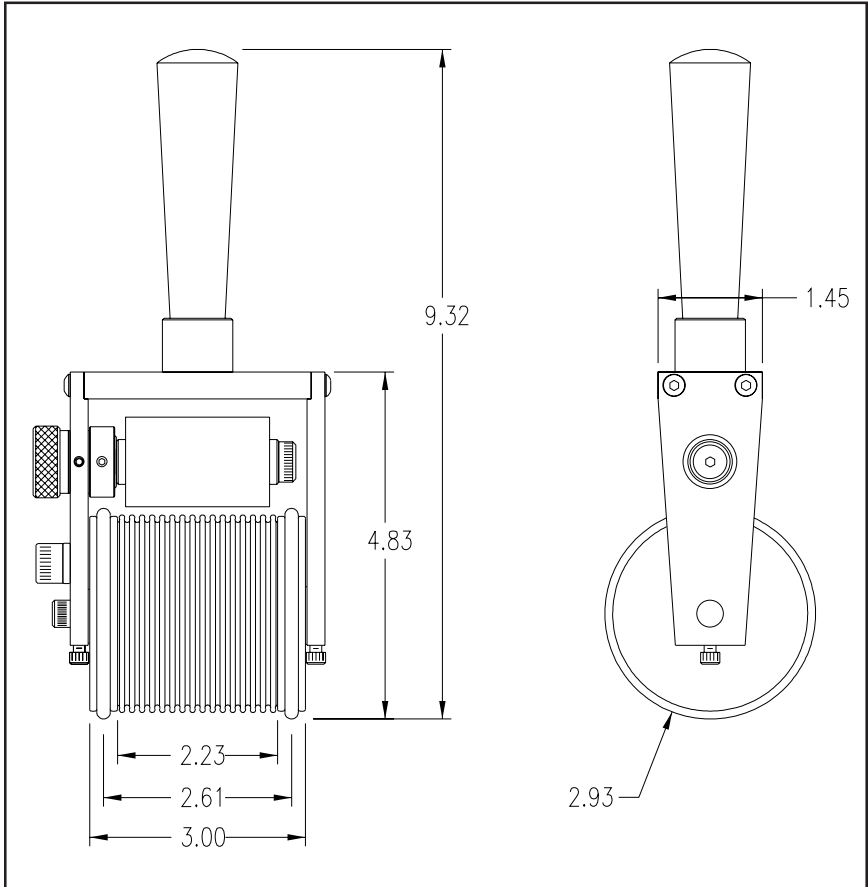

**HP-200: NET WEIGHT:** 1 LB. - 12 OZ. / 0.781 KG.

**MAXIMUM DIE SIZE - US STANDARD:** 2" (15 RIBS) X 8-3/8" LONG

**MAXIMUM DIE SIZE - METRIC CODERS ONLY:** 50.8 MM (14 RIBS) X 212.7 MM LONG

**PRINT DRUM CIRCUMFERENCE:** 9.1" (231 MM) MEASURED AT DIE FACE

**HP-200NI: NET WEIGHT:** 1 LB. - 11 OZ. / 0.753 KG.

**MAXIMUM DIE SIZE - US STANDARD:** 2" (15 RIBS) X 8-3/8" LONG

**MAXIMUM DIE SIZE - METRIC CODERS ONLY:** 50.8 MM (14 RIBS) X 212.7 MM LONG

**PRINT DRUM CIRCUMFERENCE:** 9.1" (231 MM) MEASURED AT DIE FACE

## **SPECIFICATIONS**

The Universal HP-100NI, HP-200NI and HP-200 hand printers are designed for the hand application of printed data on cartons, bags and other flat, porous surface materials

The HP-100NI and HP-200NI machines are non-indexing or continuous roll designs. The HP-200 machine is an indexing or spot printing design which allows for accurate print registration and eliminates duplication of data.

### **RIBtype® PRINTING DIES**

Universal Coders are designed to use RIBtype® printing dies which have a molded rib backing. The ribs on the back of the die snap into mating ribs in the ribtype drum cover on the print drum as shown in Figure 1. Although there are several competitive rib backed die systems available, it is very important to note that they are not all made to the same specifications and are not interchangeable.

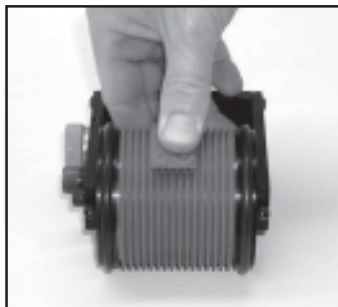

Figure 1

Dies are available in many standard character styles and sizes in sets containing a combination of individual alphabetic and numeric characters or in sets of numeric characters only. These character sets or “sorts” can be used to make up text messages and code numbers as necessary. Dies are also available in “logo” form in which a complete text message is produced on a single piece of rib backed rubber. Logo dies are much faster to change and normally produce better print quality since they are more dimensionally stable than individual characters when installed on the print drum.

### **METRIC RIBtype® PRINTING DIES**

Universal also offers RIBtype® Metric Die systems for use in countries where metric character sizes are the standard. The Metric dies are thicker and the rib spacing differs slightly from the standard printing dies therefore the two versions are not compatible. To accommodate the differences, the print drums for Metric dies are machined to a slightly different diameter from the U.S. versions.

The coder model numbers on Metric coders will have a “-T” suffix and the Metric Drum Covers have a distinct pink color.

## SPECIFICATIONS

### OPTIONAL TYPE BLOCKING KITS

When using small individual characters with only a two or three rib backing, an optional Type Blocking Kit (stock no. UR-BK) should be used to support the leading and trailing ends of the type as shown.

Characters which have only a 2 or 3 rib backing do not have the stability of the larger character sizes when snapped into the drum cover. Adding the rib backed type blocks on both ends of the code will provide added stability and prevent the characters from shifting during printing. The Type Blocks are not as thick as the Type and will not pick up ink from the Ink Roll.



FIGURE 2

### INK ROLLS & INKS

**MICROCELL ROLLS:** The standard ink rolls shipped with Universal Hand Printers are made from reticulated urethane foam. This material is one of the most durable ink roll materials available and with proper care should last in excess of one year before replacement becomes necessary. Microcell rolls should be inked with Universal No. 1150 porous coder ink only. **It is extremely important to follow the inking instructions or roll performance will be adversely affected.**

**XF NEOPRENE ROLLS:** Universal's XF Neoprene Ink Rolls are made from an extra firm density neoprene material. While not quite as durable as Microcell, the extremely fine cell structure of these rolls provides exceptionally good print quality, particularly when using small character printing dies. Due to their greater ability to compensate for slight die thickness variations, these rolls are also recommended to correct print quality problems when multiple lines of text are required.

Although these Hand Printers are not designed for production use with alcohol base marking inks, the XF Neoprene Ink Rolls are compatible with a variety of alcohol base inks. For limited use applications, slow drying alcohol base inks can be used on the XF Neoprene ink rolls for marking on Non-Porous surfaces such as metal, plastic, glass, etc. Please note that the alcohol in non-porous inks will evaporate rapidly leaving the rolls dry and hard in a relatively short period of time. After use with alcohol base inks, the rolls should be immediately removed from the coder and stored in an air tight container.

## QUICK START

### PRE-INKING THE MICROCELL INK ROLL

Universal Hand Printers are shipped from the factory fully assembled and, unless otherwise specified, include a **dry Microcell Ink Roll**. **The Ink Roll must be manually pre-inked prior to use.** The initial inking of a dry roll is a critical process. The following instructions will guide you through the inking and installation process and have your coder ready to use in a few minutes.

***Inks will stain clothing, furniture, carpeting and your hands. Rubber gloves should be worn during the following procedures.***

- 1 - Fill a clean dry container with enough ink to allow the ink roll to fully submerge.**

Microcell Ink Rolls are designed for use with Universal #1150 Ink for marking on porous surfaces.



FIGURE 3

- 2 - Carefully place the ink roll into the ink. Do not force the roll to submerge. The top surface of the roll must remain dry during this process.**

The roll should be allowed to float, undisturbed, in the container of ink. Leaving the top surface of the roll dry allows air to escape as the ink is absorbed from the bottom. **When the roll sinks under the surface of the ink, it is fully saturated.**



FIGURE 4

- 3 - Remove the ink roll from the container by inserting a screwdriver through the core.**

Let the excess ink drip into the container.

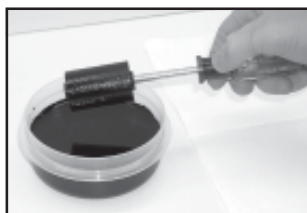

FIGURE 5

- 4 - Roll the ink roll over paper towels or a piece of scrap cardboard to remove excess ink.**

The rolls will be excessively saturated after removal from the container. Remove enough ink from the roll so the surface does not appear wet. Use a clean paper towel to blot the ink from the ends of the core before installation on the coder.

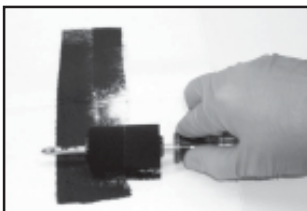

FIGURE 6

## QUICK START

### 5 - Rotate the Ink Roll Eccentric Knob until the Ink Roll Axle is at its farthest position away from the print drum.

In this position, the ink roll will not contact the print drum during installation.



FIGURE 7

### 6 - Remove the Ink Roller Axle from the coder.

Grip the Ink Roll Eccentric Adjusting Knob with one hand. Insert a 3/16" hex wrench through the access hole in the side frame of the coder and turn the Ink Roll Axle counterclockwise until loose. Pull the Ink Roller Axle out through the access hole.



FIGURE 8

### 7 - Position the ink roll between the two side frames of the coder and insert the Ink Roll Axle through the Ink Roll core.

While gripping the Ink Roll Eccentric Adjusting Knob with one hand, tighten the Ink Roll Axle using the 3/16" hex wrench.



FIGURE 9

### 8 - Install the printing dies by aligning the ribs on the die back with the matching grooves on the print drum.

Start with one end and press the die into the print drum cover until the die is fully engaged.



FIGURE 10

**Tip to make die installation easier when installing larger logo dies:** Moisten a sponge with water containing a few drops of liquid dish detergent. Lightly moisten the back of the printing die and then immediately press the die into the drum cover. Do not apply too much liquid or the dies will slip during printing. **Never apply any other lubricants such as oil or silicone or the dies will not hold properly.**



## QUICK START

### 9 - Adjust the Ink Roller Eccentric Knob to a position where the ink roll just contacts the die faces when the print drum is rotated.

Ink should only be applied to the die face, not the sides or backing of the die. Excessive contact pressure will result in an excessively wet and smudged impression.



FIGURE 11

### 10 - Your coder is now ready for use.

## RE-INKING THE MICROCELL INK ROLL

After the initial inking process, the Microcell Ink Roll can be re-inked by carefully squirting a small amount of ink on the roll surface. It is best to apply very small amounts of ink down the length of the roll in multiple places rotating the roll after each pass. Do not apply an excess amount of ink or print quality will suffer.



FIGURE 12

## MAINTENANCE

### REPLACING THE DRUM COVERING

Replacing the Drum Covering requires removal of the print drum. The following steps explain the process. For Indexing Coders, see Page 12 under Index Spring Replacement for Print Drum removal instructions.

- 1 - Lay the coder on it's side as shown and using a 5/64" hex wrench, loosen the set screw in the end of the top Side Frame.**

Do not loosen the set screw in the bottom side frame.



FIGURE 13

- 2 - Remove the two button head screws which hold the Side Frame to the Back Frame using a 3/32" hex wrench.**



FIGURE 14

- 3 - Lift the Side Frame off the coder.**

A slight wiggling action of the Side Frame may help in this process.



FIGURE 15

- 4 - Pull the Print Drum off the Axle.**

Be careful not to lose the thin brass washers located on either side of the print drum.



FIGURE 16

## MAINTENANCE

### 5 - Remove one of the Rubber Friction Bearer Rings.

It does not matter which one is removed.



FIGURE 17

### 6 - Remove the old Print Drum Cover by gripping one edge with your fingertips and rolling the cover towards the end of the Print Drum where the friction bearer was removed.



FIGURE 18

### 7 -To install the new Drum Cover, stretch one end of the cover over the end of the Print Drum without the friction bearer.

Moistening the inside of the Drum Cover with a solution of water and a few drops of liquid dish detergent will make this process easier.



FIGURE 19

### 8 - Pull the cover down in small steps, rotating the drum and pulling in different areas as you progress.

These rings are tight and installation does take a bit of effort. Do not use pliers to grip the rubber ring or it will tear.



FIGURE 20

### 9 - Replace the Rubber Friction Bearer Ring and reassemble the coder in the reverse order of the disassembly process.

Be sure the print drum brass washers are reinstalled on either side of the print drum.



FIGURE 21

## MAINTENANCE

### REPLACING THE PRINT DRUM INDEX SPRING ON THE HP-200 INDEXING CODER

Replacing the Index Spring requires removal of the print drum. Please follow these same disassembly steps for replacing the Drum Cover.

**1 -Remove the Index Stop Pin and Washer using a 5/16" hex wrench.**

If you are only replacing the Drum Cover, hold the Print Drum from rotating when this pin is being removed. As soon as the Stop Pin is removed the index spring will relax, rotating the print drum in the process.

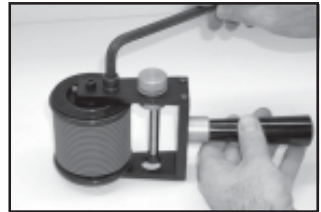

FIGURE 22

**2 -Loosen only the top Print Drum Axle Retaining Screw using a 9/64" hex wrench.**

Leaving the bottom screw tight will simplify the re-assembly procedure.

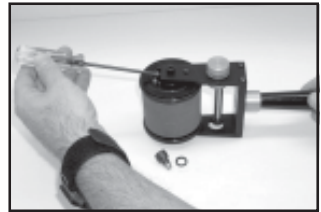

FIGURE 23

**3 -Pull the Spring Tension Adjuster out of the Axle.**

The Tension Adjuster has a flat body which fits into the slotted end of the Print Drum Axle. This part is used to pretension the Index Spring as explained later.



FIGURE 24

**4 -Remove the two button head screws that hold the Side Frame to the Back Frame using a 3/32" hex wrench.**

Note: Both Side Frames can be removed, however, for Print Drum removal purposes, remove only the Side Frame with the Ink Roll Eccentric Knob as shown in Figure 25.



FIGURE 25

## MAINTENANCE

### 5 -Lift the Side Frame off the coder.

A slight wiggling action may help disengage the Side Frame from the Print Drum Axle.



Figure 26

### 6 -Lift the Print Drum off the Axle.



Figure 27

### 7 -Remove the Index Cam.

The Index Cam on this unit enables the Print Drum to rotate 365 degrees before hitting the Stop Pin. This unique feature increases the usable area of the Print Drum for printing dies.



Figure 28

### 8 -If the Index Spring is broken, pull the broken spring out of the Print Drum through the hole where the Index Cam was removed.

After the spring is removed, shake the drum and listen for any loose spring fragments. Ensure that all loose pieces of spring are removed.



Figure 29

### 9 -Remove the small white bushing.

Set the Print Drum on two 1/2" or thicker blocks with enough gap between them to allow for the bushing to fit through. Using a flat face 3/8" - 7/16" diameter punch, gently tap the bushing from the inside to remove.

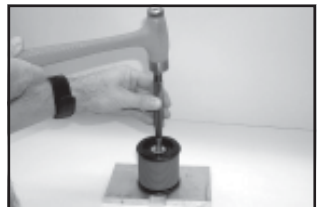

Figure 30

## MAINTENANCE

### 10 -Remove the small white bushing from the opposite end of the Print Drum.

The bushing will exit through the bottom of the Print Drum as shown.

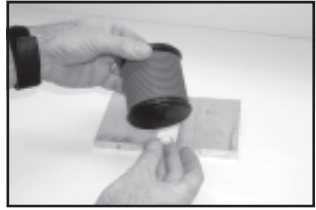

Figure 31

### 11 -Install the new Index Spring.

Insert your index finger through the large hole in the print drum and use it to guide the spring as it is inserted through the small hole. The end of the spring without the extended leg goes in first and should be guided through the center of the large bushing on the opposite end of the Print Drum.



Figure 32

### 12 -The leg of the spring which extends outward from the coil diameter must be aligned and seated in the recessed slot in the end of the Print Drum.



Figure 33

### 13 -Place the small end of the white plastic bushing in the hole where the spring was just installed.

The shoulder of this bushing is slightly larger than the hole and must be pressed into the bottom of the flange.



Figure 34

### 14 -Press the bushing into the hole.

If you have one available, using an arbor press is the ideal way to install this bushing. If you use a hammer be very careful not to damage the thin flange of the bushing during installation.



Figure 35

## MAINTENANCE

### 15 -Install the Print Drum and engage the opposite end of the spring with the slot in the Print Drum Axle.

Set the Print Drum on the bench with the small plastic bushing up. Carefully guide the end of the axle about half way into the hole and stop.

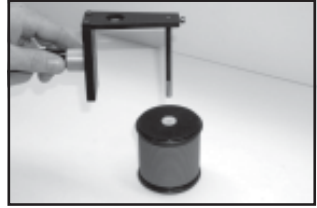

Figure 36

### 16 -Carefully turn the assembly over in order to see the opposite end of the spring.

Align the cross leg of the spring with the slot in the axle and then slide the Print Drum fully onto the axle.



Figure 37

### 17 -Install the Index Cam.

Apply a light film of grease to the shoulder and under side of the Index Cam. Align the stainless steel pin with the arced slot in the end of the print drum. The top surface of the Index Cam will be flush with the End of the Print Drum when properly installed.



Figure 38

### 18 -Install the Side Frame.

Be sure the set screw in the end of the Side Frame is not protruding into the axle hole.



Figure 39

### 19 -Reinstall the two button head screws that fasten the Side Frame to the Back Frame.

Note that the milled flat on the inside end of the Side Frame is used to align the Side Frame square with the Back Frame. While holding the two frames together firmly, tighten the button head screws.



Figure 40

## MAINTENANCE

### 20 -Install the Spring Tension Adjuster in the slot in the end of the Print Drum Axle.

The tension adjuster should be pushed fully into the axle slot.



Figure 41

### 21 -Install the Index Stop Pin & Washer.

Rotate the Print Drum in a clockwise direction until the arced slot in the Index Cam is directly below the hole for the Stop Pin. Hold the Print Drum in position while threading the Stop Pin into the hole.



Figure 42

### 22 -Tighten the Index Stop Pin using a 5/16" hex wrench.



Figure 43

The final step in the reassembly process is to adjust the tension of the Print Drum Index Spring.

## ADJUSTING THE TENSION OF THE INDEX SPRING

The Index Spring tension should be adjusted so the print drum returns in a smooth, quick motion to the home or "indexed" position. Excessive tension will cause the Print Drum to slam back hard against the Stop Pin and result in premature failure of the Index Spring.

### 1-Loosen only the top Print Drum Axle Retaining Screw using a 9/64" hex wrench.

This screw should already be loose if you have just replaced the Index Spring.

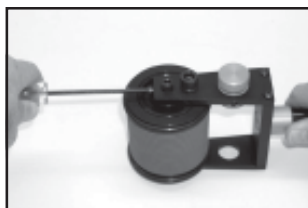

Figure 44



## MAINTENANCE

- 2 -Insert a 3/16” hex wrench in the socket head of the Spring Tension Adjuster. While holding the wrench firmly in position so it does not turn, use a 9/64” hex wrench to loosen the other Axle Retaining Screw.**

Once the second Axle Retaining Screw is loose, the Index Spring will try to relax and rotate the Tension Adjuster.

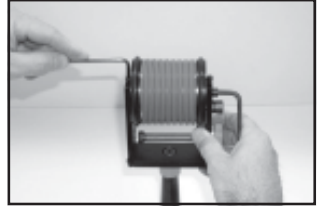

Figure 45

- 3 -To increase the spring tension, turn the Spring Tension Adjuster in a counterclockwise direction approximately 1/4 turn. Tighten the Axle Retaining Screw firmly to prevent the spring from relaxing.**

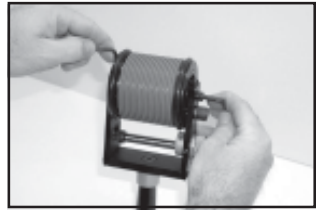

Figure 46

- 4 - Test the adjustment.**

Roll the coder across the bench top in the forward direction until it stops. Lift the Print Drum off the bench and observe the indexing action. The Print Drum should snap back to the index position in a positive motion. Repeat steps 2 & 3 as necessary until the indexing action is satisfactory. Please note that the printing dies and ink roll will add some drag to the indexing action.



Figure 47

- 5 -Tighten the remaining Axle Retaining Screw .**



Figure 48

## MAINTENANCE

### ASSEMBLY OF THE INK ROLLER ECCENTRIC

Proper installation of the Ink Roller Eccentric Assembly is critical to the performance of the coder and uniform inking of the printing dies. It is easiest to assemble these parts properly with the Side Frame removed from the coder.

#### 1 -Loosen the nylon tipped Tension Adjusting Set Screw.

This set screw is used to keep tension on the Eccentric Knob and prevent the Ink Roller from moving out of position after it is properly adjusted.

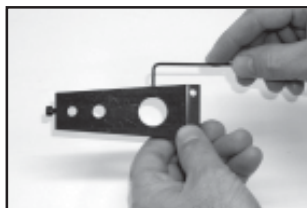

Figure 49

#### 2 -Install one of the Delrin Washers on the Eccentric Adjusting Knob.

Apply a thin film of grease on the shoulder of the Eccentric Adjusting Knob after the Delrin Washer is installed.



Figure 50

#### 3 -Insert the Eccentric Adjusting Knob through the large hole in the Side Frame.

Note: The knurled head of the Eccentric must be on the opposite side from the milled flat on the Side Frame.

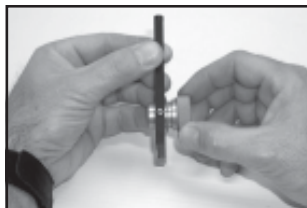

Figure 51

#### 4 -Install the remaining Delrin Washer on the Eccentric Adjusting Knob.



Figure 52

## MAINTENANCE

### 5 -Install the Locking Collar.

Set the assembly on the bench with the knurled end of the Eccentric Adjusting Knob down. Using your fingertips, press down hard on the Locking Collar. It is important that the Locking Collar is tight against the Side Frame for this assembly to work properly.



Figure 53

### 6 -Tighten the (2) Locking Collar Set Screws while holding pressure on the Locking Collar.

If you have to release the pressure against the Locking Collar in order to access the other set screw, reapply pressure before tightening the final set screw.



Figure 54

### 7 -Test the assembly by installing the Ink Roller Axle and attempting to wiggle the end of the axle.

The Ink Roller Axle must be held rigidly in position or the Ink Roller will not be parallel to the printing dies. If there is any play in the Axle, repeat Step 6 and apply greater pressure to the Locking Collar before tightening the set screws.



Figure 55

### 8 -Snug the Tension Adjusting Set Screw as necessary to provide resistance when turning the Eccentric Adjusting Knob.

The nylon tip of the set screw should be tight enough to prevent the Ink Roller Axle from moving out of adjustment during operation.



Figure 56

# POROUS HAND PRINTER HP-100NI & HP-200NI SERIES

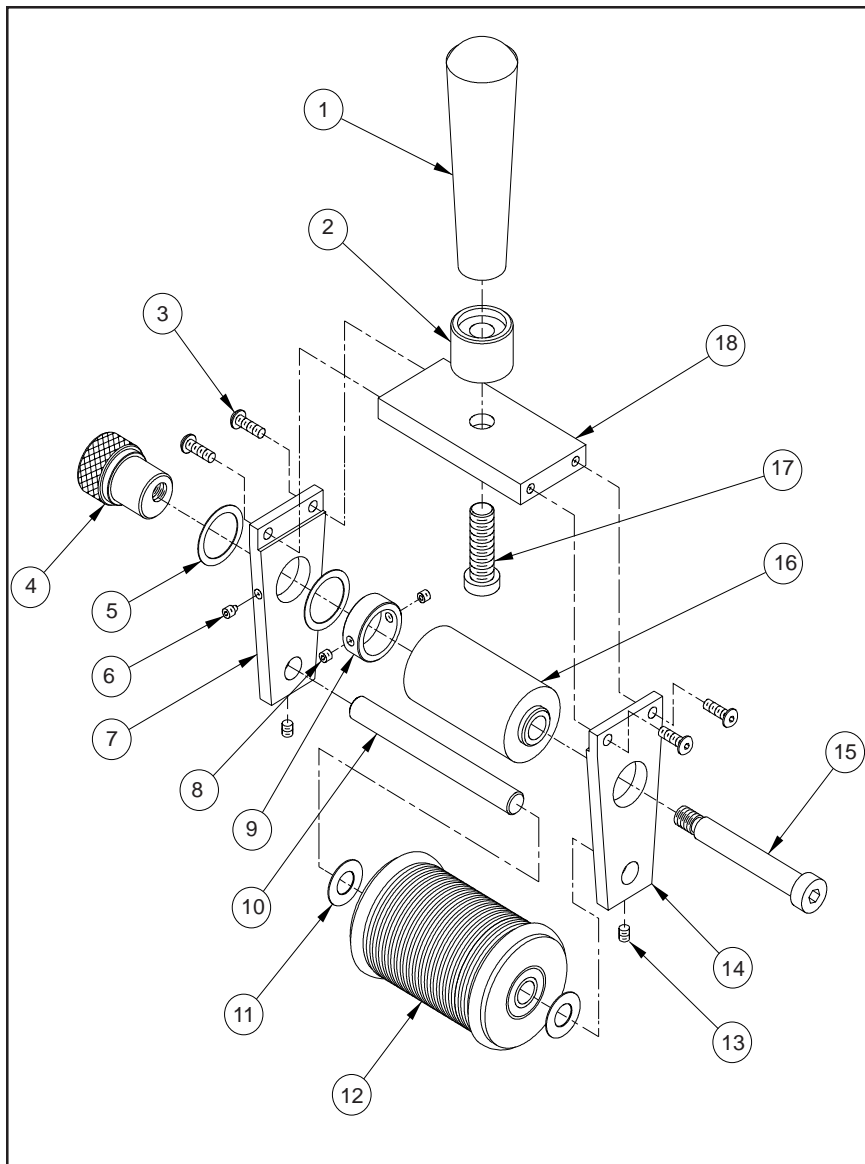

**POROUS HAND PRINTER  
HP-100NI & HP-200NI SERIES**

KEY NO.	PART NUMBER	QTY. REQ.	DESCRIPTION
1	HP-18	1	BLACK HANDLE
2	HP-17	1	HANDLE BUSHING
3	HP-10	4	SCREW, 8-32 X 1/2" BHC
4	HP-11	1	ECCENTRIC ADJUSTING KNOB
5	HP-42	2	DELTRIN WASHER
6	CF-05	1	SET SCREW, 8-32 X 3/16" S.S. NTS
7	HP-08	1	HP-100NI SIDE FRAME FOR TENSION SCREW
	HP-28	1	HP-200NI SIDE FRAME FOR TENSION SCREW
8	HP-13	2	SET SCREW, 8-32 X 1/8" CPS
9	HP-12	1	LOCKING COLLAR
10	HP-05	1	PRINT DRUM AXLE
11	HP-04	2	3/8" BRASS FLAT WASHER
12	HP-100NI-PDA	1	HP-100NI PRINT DRUM ASSEMBLY
	HP-100NI-PDA-T	1	HP-100NI-T PRINT DRUM ASSEMBLY - METRIC
	HP-200NI-PDA	1	HP-200NI PRINT DRUM ASSEMBLY
	HP-200NI-PDA-T	1	HP-200NI PRINT DRUM ASSEMBLY - METRIC
13	HP-06	2	SET SCREW, 8-32 X 3/16" CPS
14	HP-07	1	HP-100NI SIDE FRAME
	HP-27	1	HP-200NI SIDE FRAME
15	HP-14	1	INK ROLLER AXLE
16	HP-100RM	1	MICROCELL INK ROLL - STANDARD
	HP-100RX	1	XF NEOPRENE INK ROLL - OPTIONAL
17	HP-15	1	HANDLE BOLT, 3/8-16 X 1-1/2
18	HP-16	1	BACK FRAME

**POROUS HAND PRINTER PRINT DRUM  
HP-100NI & HP-200NI SERIES**

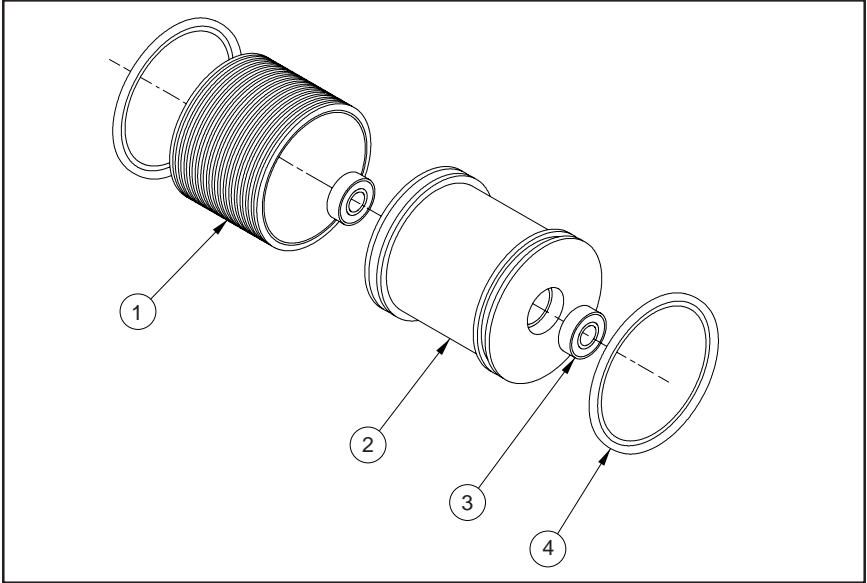

KEY NO.	PART NUMBER	QTY. REQ.	DESCRIPTION
1	HP-21	1	HP-100NI RIBtype® RING
	MC-21	1	HP-200NI RIBtype® RING
	HP-21T	1	HP-100NI RIBtype® RING - METRIC
	MC-21T	1	HP-200NI RIBtype® RING - METRIC
2	HP-101	1	HP-100NI CENTER TUBE/END CAP ASSY.
	HP-201	1	HP-200NI CENTER TUBE/END CAP ASSY.
	HP-101-T	1	HP-100NI CENTER TUBE/END CAP ASSY - METRIC
	HP-201-T	1	HP-200NI CENTER TUBE/END CAP ASSY - METRIC
3	HP-02	2	PRINT DRUM BEARING
4	HP-03	2	HP-100NI / HP-100NI-T FRICTION BEARER RING
	MC-01	2	HP-200NI / HP-200NI-T FRICTION BEARER RING

**PARTS LISTS FOR INDEXING HAND PRINTER  
ON THE FOLLOWING PAGES**

# POROUS HAND PRINTER HP-200 SERIES

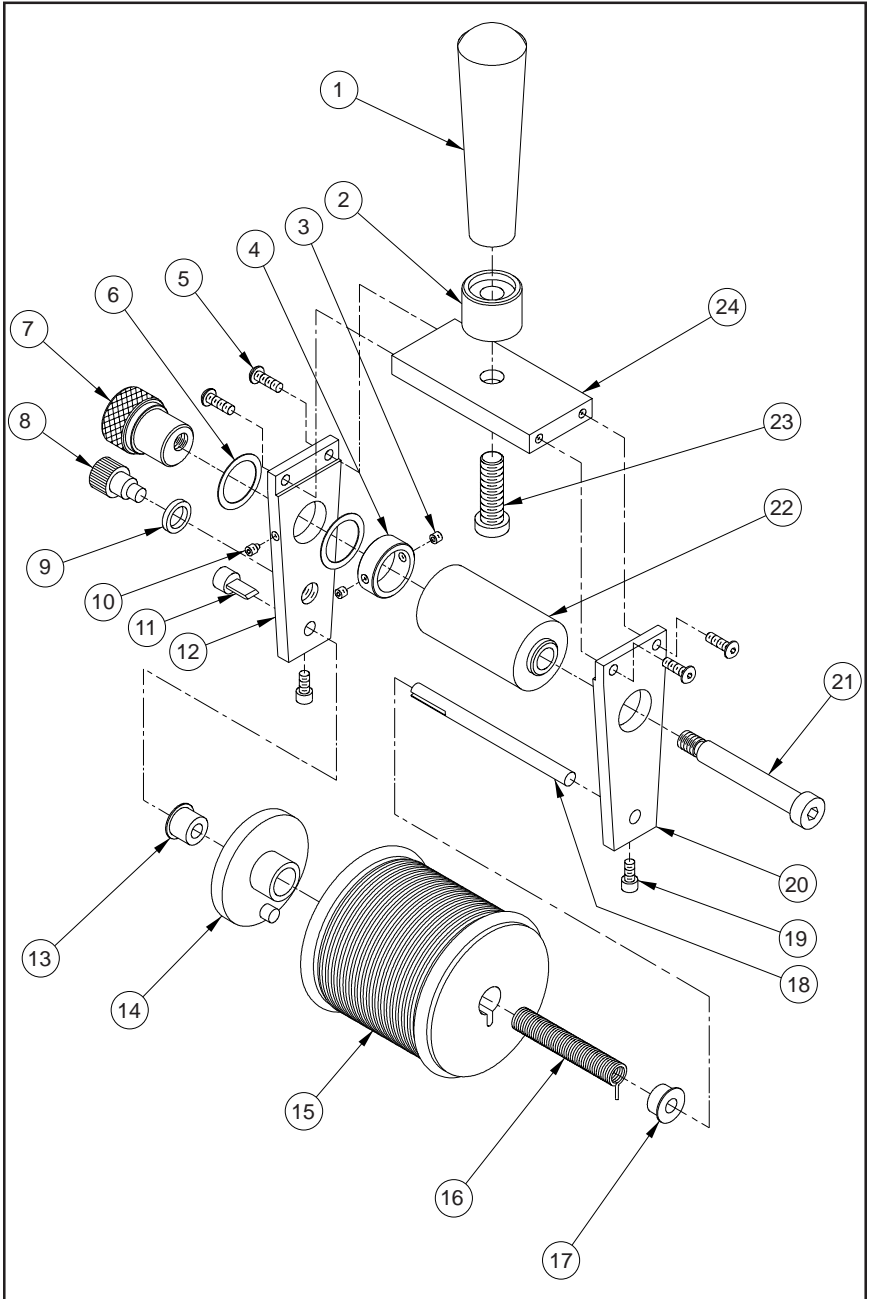



## **POROUS HAND PRINTER HP-200 SERIES**

<b>KEY NO.</b>	<b>PART NUMBER</b>	<b>QTY. REQ.</b>	<b>DESCRIPTION</b>
1	HP-18	1	BLACK HANDLE
2	HP-17	1	HANDLE BUSHING
3	HP-13	2	SET SCREW, 8-32 X 1/8" CPS
4	HP-12	1	LOCKING COLLAR
5	HP-10	4	SCREW, 8-32 X 1/2" BHC
6	HP-42	2	DELTRIN WASHER
7	HP-11	1	ECCENTRIC ADJUSTING KNOB
8	HP-36	1	STOP PIN
9	HP-43	1	STOP PIN WASHER
10	CF-05	1	SET SCREW, 8-32 X 3/16" S.S. NTS
11	HP-41	1	SPRING TENSION ADJUSTER
12	HP-30	1	HP-200 SIDE FRAME FOR TENSION SCREW
13	HP-33	1	INDEX CAM BUSHING
14	HP-22	1	INDEX CAM ASSEMBLY
15	HP-200-PDA	1	HP-200 PRINT DRUM ASSEMBLY
	HP-200-PDA-T	1	HP-200-T PRINT DRUM ASSEMBLY - METRIC
16	HP-09	1	INDEX SPRING
17	HP-32	1	PRINT DRUM BUSHING "B" - SMALL
18	HP-35	1	PRINT DRUM AXLE - SLOTTED
19	HP-40	2	SCREW, 8-32 X 3/8" SHC
20	HP-29	1	HP-200 SIDE FRAME
21	HP-14	1	INK ROLLER AXLE
22	HP-100RM	1	MICROCELL INK ROLL - STANDARD
	HP-100RX	1	XF NEOPRENE INK ROLL - OPTIONAL
23	HP-15	1	HANDLE BOLT, 3/8-16 X 1-1/2
24	HP-16	1	BACK FRAME

## POROUS HAND PRINTER PRINT DRUM HP-200 SERIES

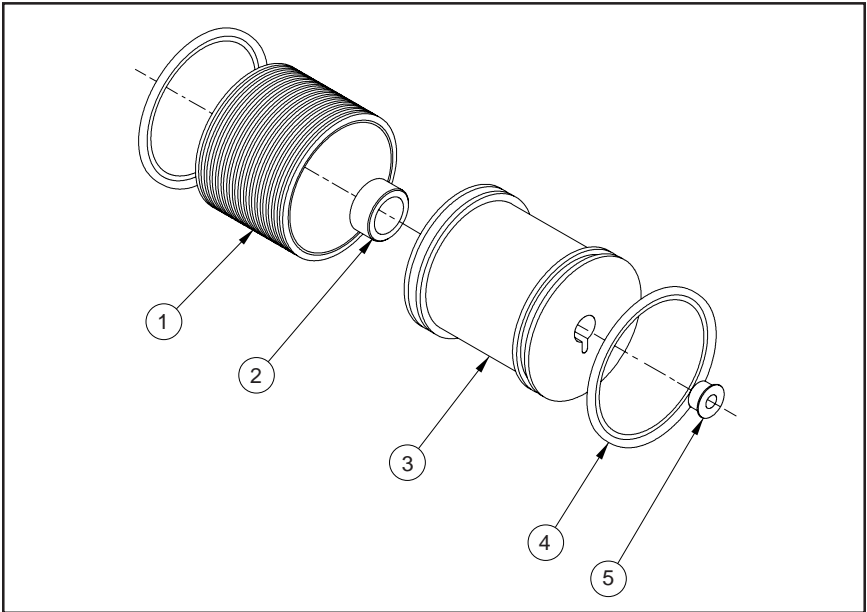

KEY NO.	PART NUMBER	QTY. REQ.	DESCRIPTION
1	MC-21	1	HP-200 RIBtype® RING
	MC-21T		HP-200 RIBtype® RING - METRIC
2	HP-31	1	END CAP "A" BUSHING
3	HP-202	1	HP-200 CENTER TUBE/END CAP A & B BUSHING ASSEMBLY
	HP-202-T		HP-200T CENTER TUBE/END CAP A & B BUSHING ASSY. METRIC
4	MC-01	2	HP-200 BEARER RING
5	HP-32	1	END CAP "B" BUSHING